



OPERATING MANUAL AND SPARE PARTS LISTS

Submersible Pumps

P 220 P 20 P 30 P 40 ND P 40 HD P 60 ND P 40 CS
P 220 A P 20 A P 30 A P 40 ND A P 40 HD A P 60 ND A

	Page
Introduction	2
1 Use	2
1.1 Intended Use	2
1.2 Unintended Use	2
1.3 CE Mark	3
1.4 Disposal	3
2 Safety Information on the Submersible Pump	4
2.1 Signs and Symbols	4
2.2 General Safety Information	5
3 Becoming Familiar with the Product	6
3.1 Operating Elements on the Submersible Pump	6
3.2 Auras Automatic System	7
3.2.1 Switch positions	7
3.3 Transport and Storage	8
3.4 Power Supply	8
3.5 Frost	9
3.6 Overheating/Overloading	9
4 Preparatory Measures	12
4.1 Controlling the Direction of Rotation (only for models with a three-phase current supply) 12	
4.2 Connecting and Securing the Discharge Hose	12
5 Using the Submersible Pump	14
5.1 Correct Positioning	14
5.2 Switching On/Off	15
5.3 After Use/Cleaning	15
6 Useful Accessories	16
6.1 Base Suckers	16
6.1.1 Installing the base sucker	16
6.1.2 Using the base sucker	16
6.2 External Float Switch	16
6.2.1 Connecting the float switch	16
6.3 Non-return Valve	17
6.3.1 Installing a non-return valve	17
6.4 Hose Diameter Enlargement/Reduction	17

	Page
7 Maintenance and Service	18
7.1 Checks	18
7.1.1 Inspection intervals	18
7.1.2 Checking seals and oil	18
7.2 Controlling and Minimising Wear	19
8 First Aid for the Submersible Pump	20
8.1 Rating Plate	20
9 Contact	21
10 Performance Curves & Technical Data	22
11 Drawings and Parts Lists	24
11.1 Exploded Diagram, P 220 - P 220 A	24
11.2 Parts List, P 220 - P 220 A	25
11.3 Exploded Diagram, P 20 - P 20 A	26
11.4 Parts List, P 20 - P 20 A	27
11.5 Exploded Diagram, P 30 - P 30 A	28
11.6 Parts List, P 30 - P 30 A	29
11.7 Exploded Diagram, P 40 ND - P 40 ND A	30
11.8 Parts List, P 40 ND - P 40 ND A	31
11.9 Exploded Diagram, P 40 HD - P 40 HD A	32
11.10 Parts List, P 40 HD - P 40 HD A	33
11.11 Exploded Diagram, P 60 ND - P 60 ND A	34
11.12 Parts List, P 60 ND - P 60 ND A	35
11.13 Exploded Diagram, P 40 CS	36
11.14 Parts List, P 40 CS	37
12 EC Declaration of Conformity	38

Introduction

We are very pleased that you have chosen a submersible pump from Auras, a high quality brand!

Please observe the information in this operating manual to ensure your submersible pump enjoys a long, trouble-free service life!



NOTE

Auras Pumpen GmbH & Co. KG is not considered liable for personal injury or property damage resulting from improper use of the submersible pump!

Only use the Auras submersible pump in accordance with the types of use described in this manual!

The Auras pump is a portable submersible pump. Prior to a fixed installation, the installation conditions must be checked and evaluated by experts. Auras Pumpen GmbH & Co. KG is not considered liable for any consequential damage (personal injury or property damage) resulting from improper installation.

1

Use

1.1

Intended Use

Auras submersible pumps are conceived for the areas of use and working conditions described below:

- Auras submersible pumps may only be used in their condition on delivery. Modifications are not permitted.
- For pumping construction trenches, cellars, ponds, swimming pools, etc. dry.
- For preventing groundwater seeping into construction trenches for a reasonable time in accordance with local regulations (groundwater maintenance).
- For use as a groundwater pump, e.g. to water gardens and agricultural areas.
- Auras submersible pumps may only be operated in water within a temperature range from 0 to 35 °C.
- The maximum immersion depth is 10 meters (below the water surface).
- **Model P40 CS only:** Use in sewage containing faeces.

1.2

Unintended Use

Auras submersible pumps have **NOT** been conceived for the following:

- Use in potentially explosive atmospheres.
- Use in combustible liquids.
- Use in liquids such as: oil, chemicals, foodstuffs, sewage containing faeces (except Model P40 CS), liquids containing long-stranded components.

1.3**CE Mark**

This submersible pump from Auras fulfils all the necessary requirements stipulated in the applicable EU Directives:

(DIRECTIVE 2006/42/EC OF THE EUROPEAN PARLIAMENT AND OF THE COUNCIL of 17 May 2006 on machinery, and amendment to Directive 95/16/EC (revised version) significant to the EEA).



Conformity of the product to the above directives is confirmed by the CE Mark applied to the device. The Declaration of Conformity can be viewed in full at the following address:

Auras Pumpen GmbH & Co. KG
Borsigallee 14
60388 Frankfurt / Main

1.4**Disposal**

When your Auras submersible pump has come to the end of its service life, bring the old unit to a collection point provided by your local waste disposal authorities (e.g. recycling centre, waste disposal plant).



The adjacent symbol indicates that the old unit must be disposed of separated from household waste. According to the laws on electrical and electronic equipment, the owners of old units are legally obliged to dispose of old electronic and electrical devices in a separate waste container.

Please help and make a contribution to environmental protection by not throwing old equipment in household waste.

2

Safety Information on the Submersible Pump

Dear Customer,
Your safety is very important to us!

Therefore, please read the safety information carefully and thoroughly. Always observe the general information regarding safety provided in this chapter as well as the specific safety information in the following chapters.



NOTE

Auras Pumpen GmbH & Co. KG is not considered liable for damage or injury caused by any of the following reasons:

- Disregard for the safety information
- Improper handling or use
- Use with non-approved accessories / spare parts
- Failure to observe the legal inspection requirements and maintenance recommendations

2.1

Signs and Symbols

This operating manual contains the following signs and symbols to indicate various risks and information:

Level of Danger	Associated Symbol	Signal Word	Definition
Risk of fatal injury		DANGER	Failure to observe the safety information will result in fatal or serious personal injury.
Serious injury		WARNING	Failure to observe the safety information could result in fatal or serious personal injury.
Serious injury through electric shock			Extra indication of the basic risks from electricity.
Minor injury and property damage		CAUTION	Failure to observe the safety information could result in minor personal injury and/or property damage.
Information		INFORMATION	Information on preventing injuries to persons and damage to the environment and/or equipment.
Tip		TIP	Helpful information on using the submersible pump.

2.2

General Safety Information



NOTE

Not all the possible risks which could occur when using the equipment can be listed in this operating manual. Always work in a cautious manner and observe the local safety regulations.



DANGER



Risk of electric shock

- Incorrectly repaired submersible pumps could be the source of incalculable safety risks. Always have repairs completed by authorised, skilled personnel!
- Even low electrical currents can lead to serious or even fatal injuries!
 - Never lift the submersible pump by the cable.
 - Lay the cables so that they cannot be damaged.
 - Never put a damaged submersible pump into operation.



DANGER

Non-functional safety equipment

- Safety equipment which has been put out of service represents a major safety risk! Never put the safety equipment on the submersible pump out of service!

Risks for children

- This device may be used by **children** aged 13 or over and by persons with restricted physical, sensory or mental capability or lack of experience and knowledge when they are under supervision or have received the necessary instruction regarding safe use of the device and understand the risks involved. **Children** must not play with the device. Cleaning and **user maintenance** must not be completed by **children** without the appropriate supervision.

Risk of explosion

- Pumps can be the cause of serious explosions! The submersible pumps are not designed for use in potentially explosive atmospheres! Never use the submersible pumps in such areas!



WARNING

Drowning

- Persons could be drawn under water and drown. Never operate the submersible pump in containers/bodies of water in which people are standing.

Mutilation

- The submersible pump could start up accidentally and cause severe injuries! Disconnect the submersible pump from the mains power supply before opening it or beginning any work on it!

Back injuries, crushing

- The submersible pump is heavy and could cause serious injuries, e.g. if it falls over. Always use suitable tools and aids to transport the submersible pump.



CAUTION

Damage to the submersible pump

- Inappropriate electrical voltages could damage the submersible pump. Only operate the submersible pump within the specified voltage range (indicated on the respective rating plate).

3

Becoming Familiar with the Product

This chapter will help you become familiar with the operating elements on the submersible pump and provides information on transporting it properly.

3.1

Operating Elements on the Submersible Pump

Auras submersible pump are equipped with the following elements:

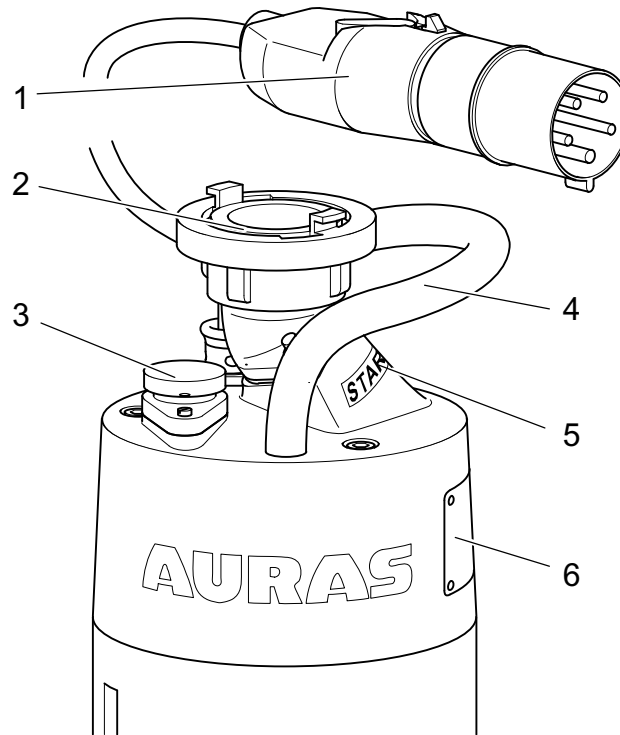

1. Power connector with three-phase reversing switch (models P220 and P60 ND have no three-phase reversing switch)
2. Discharge
3. In the case of a submersible pump with Auras Automatic: Selector switch with setting "A" for Automatic operation and "C" for Continuous operation
4. Handle
5. Start label
6. Rating plate



NOTE

The submersible pump starts when it is connected to the mains power supply via the power connector.

3.2 Auras Automatic System

The Auras Automatic system (indicated by the "A" in the model name) operates without any moving parts.

The water level is monitored by two electrodes mounted in the pump housing. If the top and bottom electrodes are surrounded by water (Fig. 1), the submersible pump starts up. The water level sinks (Fig. 2). Pump operation is stopped when the water level has dropped below the bottom electrode (Fig. 3).



TIP

The control voltage of the electrodes is only 18 V and completely harmless for human beings.

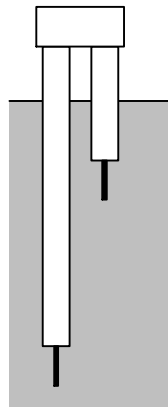

Fig. 1

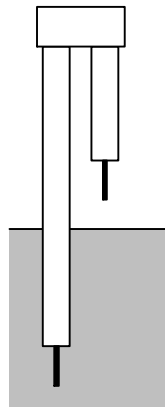

Fig. 2

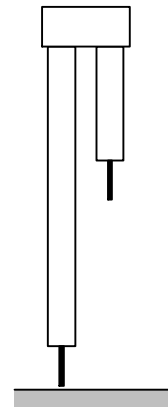

Fig. 3

3.2.1 Switch positions

In order to activate Auras automatic mode, move the selector switch to the position illustrated in Fig. 1.

In order to deactivate Auras automatic mode, move the selector switch to the position illustrated in Fig. 2.

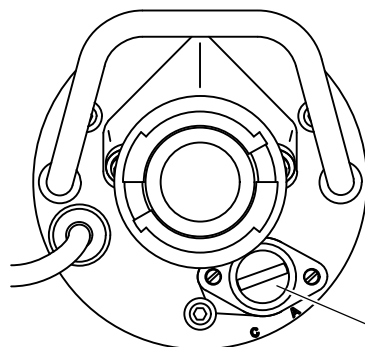

Fig. 1

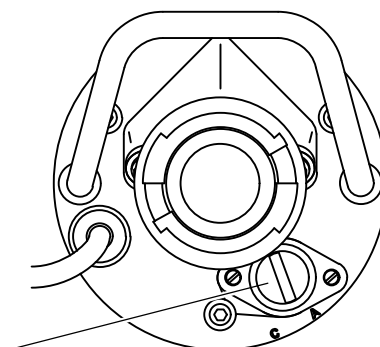

Fig. 2

Selector switch

3.3 Transport and Storage



DANGER



Electric shock

Defective cables can lead to serious injuries and damage. Never attempt to lift the submersible pump using the power cable or hose because the parts could be damaged as a result.

Always use the handle to transport, lift and set down the submersible pump.



WARNING

Back injuries, crushing

The submersible pump is heavy and could cause serious injuries, e.g. if it falls over. Always use suitable tools and aids to transport the submersible pump.

Observe the following points in the case of transport and storage:

- Always use the handle to transport the pump.
- Store the submersible pump at a location protected from frost.

3.4 Power Supply



DANGER



Fatal electric shock

Incorrectly installed power sockets could be the cause of fatal electric shocks. Only operate the submersible pump via properly installed and approved power sockets.

Only allow properly skilled electricians to complete work on electrical lines and systems.



NOTE

- The fuse at the power source must comply with the specified values (refer to the Technical Data from Page 22). When the pump motor is started up, it briefly requires a much higher current for a short time than for the operating current.
- The mains voltage to which the submersible pump is connected may deviate maximally +/- 5% from the voltage specified on the submersible pump's rating plate. In the case of greater deviations, the submersible pump will be damaged.
- If you operate the submersible pump via a portable power generator, pay attention that it is capable of producing the higher starting current which is required briefly when the submersible pump is switched on.
- Only switch the submersible pump on when the correct mains voltage and frequency are provided (particularly when using a portable generator). Otherwise, the pump electronics could be damaged. Contact an electrician in case of doubt!
- If a portable generator is used for the power supply, always disconnect the submersible pump from the generator before switching the generator off. This prevents any possible damage to the submersible pump.
- If the electrical power is drawn from a distributor (multicontact plug), pay attention that it will not be overloaded as a result of all the other devices connected.

3.5

Frost



CAUTION

Clogging of the hose

The pump could be overloaded and damaged as a result of clogging. If the hose has frozen and/or there is ice in the hose, thaw it or change it before starting the pump.



NOTE

The submersible pump is conceived for use at water temperatures from 0 - 35 °C. If the submersible pump is frozen, do not thaw the submersible pump by exposing it to extreme temperatures (e.g. naked flames or hot air guns). The material from which the pump is made may not be able to withstand such extreme temperature fluctuations and be damaged.

Let the pump thaw slowly at moderate temperatures.

Use of the submersible pump at temperatures under 0 °C is only permitted when the submersible pump is fully immersed in water or under the frozen surface.

3.6

Overheating/Overloading

The thermal sensors in the submersible pumps are switched to the motor contactor in such a way that the submersible pump is automatically switched off in the event of overheating or overloading.

4

Preparatory Measures

This section provides information on preparing the submersible pump for use.

4.1

Controlling the Direction of Rotation (only for models with a three-phase current supply)



DANGER

Fatal electric shocks



Electric shocks possible if the phases are swapped.

The AC phases may only be altered by correspondingly skilled personnel. Disconnect the submersible pump from the mains power supply beforehand and lock it against being connected/switched on again without authorisation.



WARNING

Fire and short circuit

Cable fires and short circuits possible due to incorrect extension cables.

Only use extension cables with appropriate dimensioning. Pay attention that the plug connections are splashproof.

Always wind the cable up fully to prevent a so called coil effect which could lead to a cable fire.



NOTE

In the event of incorrect direction of rotation, the submersible pump motor could overload and be damaged as a result.

Submersible pumps are switched to rotate clockwise at the factory in accordance with VDE directives.

Despite this, incorrect rotation is possible as a result of three-phase AC. Therefore, check the direction of rotation each time before the pump is put into operation.

Proceed as follows to check the direction of rotation:

1. **Only in the case of automatic pumps:** Set the selector switch to Position "C" for continuous operation.
2. Tip the pump to a slight angle.
3. Switch on the mains power supply briefly (approx. 1 second) (refer to Switching On/Off on Page 15).
4. If the pump motor rotates in the right direction, the submersible pump jolts visibly and perceptibly in the direction of the mark (arrow on the start label).
5. If the submersible pump jolts in the opposite direction to the mark (arrow on the start label), actuate the three-phase reversing switch on the power connector, if available, or call a properly qualified electrician to swap the corresponding phases.

4.2

Connecting and Securing the Discharge Hose



WARNING

Flailing of the discharge hose

The discharge hose can flail around when under extreme pressure causing serious injuries and/or property damage. Hold the hose firmly or fix it adequately.



CAUTION

Risk of flooding

The hose could loosen from the discharge if it is not tightened properly.

Ensure that the discharge hose is tightened correctly and sufficiently and that the area in which the pumped water will be drained can take the water without any risk.

NOTE

- The pumped water could contain pollutants which represent a risk to the environment. Ensure that water containing pollutants is collected and disposed of properly, according to the applicable regulations.
- When laying the hose, pay attention there are no kinks in it.
- Lay the hose so that there is no risk of tripping over it.
- Protect the hose from being driven over.
- Do not lay the hose over sharp edges or on surfaces which could damage it.

TIP

If the submersible pump is to be used in confined shafts in which the hose will run vertically upwards, we recommend use of a non-return valve (particularly for Automatic operation). This prevents an unwanted return flow of the water if the submersible pump is switched off.

Proceed as follows to connect the corresponding discharge hose to the discharge of the submersible pump:

1. Fit the hose connection on the discharge of the submersible pump. When doing so, pay attention that the surfaces are clean and the seals are in good condition. The hose connection must make full contact.

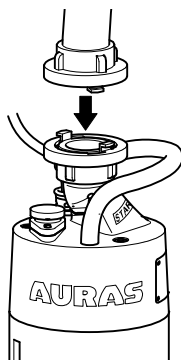

2. Turn the hose connection clockwise to tighten it. Use a coupling wrench, if necessary.

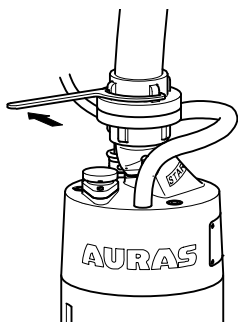

3. The discharge hose must be laid to a location which can take the quantity and type of water pumped without any risks. Secure the end of the hose from flailing, unauthorised access and slipping.

5

Using the Submersible Pump

This section explains how to operate the submersible pump safely, considerably and efficiently.

5.1

Correct Positioning



DANGER



NOTE

Fatal electric shocks

Never attempt to lift the submersible pump by the power cable or hose.

Always use the handle to transport, lift and set down the submersible pump.

Information on positioning:

- The diffuser and impeller could be subject to extreme wear if the pump is positioned incorrectly. Do not place the submersible pump on clay or sandy ground. Hang the submersible pump in such pump sumps by the handle so its base is 2 - 3 cm above the ground.
- The impeller could become blocked in bodies of water in which a great deal of foliage etc. has collected. Place the submersible pump inside an additional cage in such circumstances. This also helps to filter out foliage and such.
- If you use the Auras automatic system, set the pump up as vertically as possible. If placed in a lying position, automatic mode cannot operate correctly and the submersible pump could run dry.

Proceed as follows to position the submersible pump:

1. If the pump is to be lowered into a shaft, attach a sufficiently strong rope or such to the handle and lower the submersible pump carefully. Do not lower the submersible pump by the cable or hose.



TIP

If you want to use the Auras pump in automatic mode, do not forget to set the selector switch to the necessary position.

2. Pay attention that the submersible pump stands firmly in the water. Secure it from tipping over, if necessary.
3. Set the submersible pump down in the water on a firm piece of ground or suspend it in the water from a sufficiently strong rope, 2 - 3 cm from the ground.

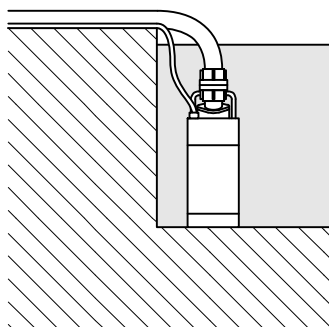

Positioning on firm ground

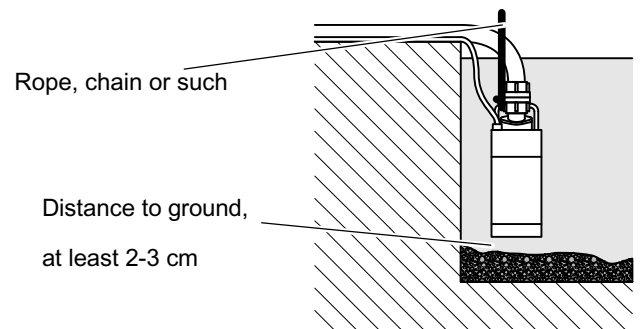

Positioning on loose ground

5.2

Switching On/Off



CAUTION

Never leave the submersible pump unattended when in operation. Remain on site to prevent any accidents etc.

When you have positioned and set up the submersible pump as described, connect the power connector to the power socket.

The submersible pump starts operation automatically or begins operation when the Auras automatic system is activated.

To switch the submersible pump off, simply disconnect the power connector from the power socket.

5.3

After Use/Cleaning

Elements pumped up with the water, e.g. cement, plaster or mud, could dry and block moving parts of the submersible pump. Flush the submersible pump thoroughly with clean water after use.

6

Useful Accessories

Our homepage at www.tauchpumpen.de provides a wide range of useful accessories. This chapter describes the installation of the most frequently used accessories:

6.1 Base Suckers

If you want to pump your cellar practically dry, for example, a base sucker from Auras can be used. The Auras base suckers pump the water practically to floor level.

6.1.1 Installing the base sucker

1. Disconnect the submersible pump from the power supply.
2. Lay the submersible pump on its side.
3. Loosen the three nuts in the base plate on the underside of the submersible pump.
4. Remove the base plate.
5. Mount the base sucker on the underside of the submersible pump. The collar must point to the air intake of the submersible pump.
6. Tighten the three nuts in the base plate on the underside of the submersible pump.

6.1.2 Using the base sucker

- Position the submersible pump with Auras base sucker installed at the lowest possible point of the area to be pumped.
- If you use a submersible pump with the Auras automatic system, switch to Continuous operation.
- Plug the power connector of the submersible pump in a power socket. The submersible pump starts its pumping operation.

6.2 External Float Switch

If your pump is not equipped with the Auras automatic system but you need an automatic operation option despite this, we recommend the float switch from Auras.

6.2.1 Connecting the float switch



NOTE

Running dry could damage the submersible pump. Ensure the float switch switches the submersible pump off in good time. Fix the cable of the float switch so that the float hangs vertically down when the water level is low and, as a result, switches the pump off.

1. Plug the power connector of the submersible pump in the connection on the float switch (see below).

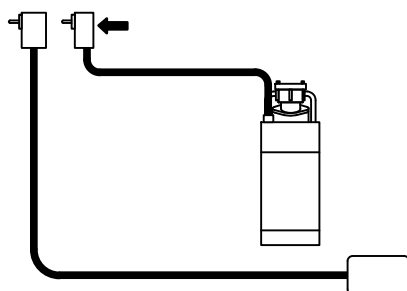

Float switch connection with 230 V submersible pump

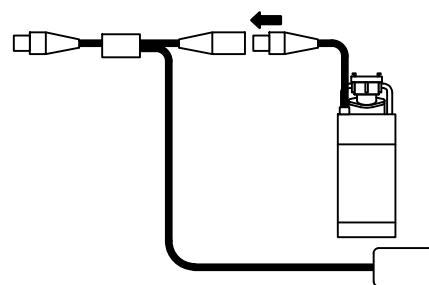

Float switch connection with 400 V submersible pump

2. Set-up the submersible pump as described.
3. Position the float in the area/container to be pumped dry so that it can move freely (Position A). Fix the cable of the float switch so that when the water level is low, the float hangs above the ground/base (Position B) and does not make contact with it.

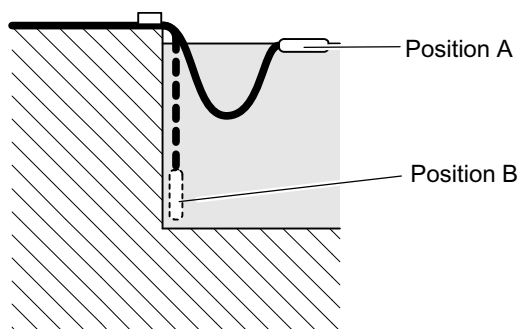

4. Plug the float switch power connector in the power socket to switch the submersible pump on.

6.3 Non-return Valve

If the submersible pump is to be used in narrow shafts in which the discharge hose is fed vertically upwards, we recommend the installation of a non-return valve. This ensures that the water still in the hose after the pump has stopped does not flow back into the sump. It is of particular advantage when using a submersible pump with automatic system or a float switch because the submersible pump is not reactivated due to water flowing back.

6.3.1 Installing a non-return valve

1. Assemble the non-return valve directly on the discharge of the submersible pump.
2. Connect the discharge hose to the non-return valve and lay it as described.

6.4 Hose Diameter Enlargement/Reduction

Auras has a wide range of solutions in cases where hose diameters must be enlarged or reduced.



TIP

Please note that the pressure increases when the diameter is reduced and decreases when the diameter is enlarged.
If the hose diameter is reduced, the end of the hose must be particularly well fixed.

7

Maintenance and Service



DANGER



Fatal electric shocks

Incorrectly serviced submersible pumps represent a risk of fatal injury!

Always have maintenance and service work completed by skilled personnel trained for the tasks.

Follow the information in this chapter to ensure your submersible pump enjoys a long, trouble-free service life.

7.1

Checks



WARNING

Mutilation

The submersible pump could start up accidentally and cause severe injuries! Disconnect the submersible pump from the mains power supply and lock it against being switched on without authorisation before opening or working on it!



CAUTION

Risk of slipping

Escaping oil represents a risk of slipping and, thus, to bad falls. Clear it up immediately and properly.



NOTE

Information on maintenance

- When completing checks, pay attention that escaping oil is always cleaned up properly, according to the appropriate regulations. Otherwise, it could lead to environmental damage. Clear up escaping oil immediately and properly!
- Observe local inspection requirements (e.g. for Germany: the BGV A3).

7.1.1

Inspection intervals

Period	Condition
After two weeks	<ul style="list-style-type: none"> • Submersible pump is new • New seals have been installed
Monthly	<ul style="list-style-type: none"> • Operation in very dirty water
Every two months	<ul style="list-style-type: none"> • Operation in clean water

7.1.2

Checking seals and oil

The seals should be checked in a protected room with sealed floor.

Proceed as follows to check the seals:

1. Disconnect the submersible pump from the mains power supply and lock it against being switched on again without authorisation.
2. Lay the submersible pump on its side so that an oil sump can be placed under the oil drain plug. Secure the pump from moving its position inadvertently.
3. Place a sufficiently large oil sump under the oil drain plug (for oil quantity, refer to Technical Data Page 22).
4. Remove the oil drain plug, including the sealing ring, from the submersible pump housing. The oil flows into the oil sump provided.
5. Check the sealing ring and replace with a new one, if necessary.

6. Check the seals and oil:
 - Seals and oil are correct when ONLY oil flows out of the submersible pump.
 - Seals and oil must be renewed when:
 - the oil quantity has dropped appreciably,
 - the oil has a light, yellow-brown colouration,
 - the oil is viscous,
 - there is a distinct water separation in the oil.
7. Complete the necessary repairs:
 - replace the seals,
 - refill/change the oil (for details, refer to the Technical Data Page 22).
8. Insert and tighten the oil drain plug including the sealing ring again.

7.2

Controlling and Minimising Wear



WARNING

Mutilation

The submersible pump could start up accidentally and cause severe injuries! Disconnect the submersible pump from the mains power supply and lock it against being switched on without authorisation before opening or working on it!

Check the level of wear to the impeller, diffuser, wearing lining and impeller cover at regular intervals.

Too much slack between the impeller and diffuser results in a considerable increase in wear.

Regular fine adjustment of the diffuser and impeller by skilled personnel can lengthen the service life of these parts considerably.

8

First Aid for the Submersible Pump

This chapter explains how to recognise and clear faults.



DANGER



Fatal electric shocks

Always disconnect the power connector before starting to locate faults!

Always have electrical faults checked and cleared by an appropriately skilled electrician.

Fault / Problem	Possible Cause	Solution
Too little power	<ul style="list-style-type: none"> • Diffuser and/or impeller worn • Incorrect direction of rotation of motor • Discharge hose kinked • Discharge hose too long • Motor cable longer than standard length • Current fluctuations too extreme 	<ul style="list-style-type: none"> • Change the components concerned • Actuate the three-phase reversing switch • Re-lay the discharge hose and secure • Use shorter discharge hose • Use shorter motor cable • Current fluctuations, see Page 10
Pump motor does not start	<ul style="list-style-type: none"> • Power cable is defective • Cable inside the submersible pump is defective • Loose connections of cables/ connectors 	<ul style="list-style-type: none"> • Always have these faults cleared by an appropriately skilled electrician!
Automatic mode is not activated	<ul style="list-style-type: none"> • Electrode slot in the motor housing is blocked • Electrode is damaged • Electrode is stuck 	<ul style="list-style-type: none"> • Clean the electrode slot • Have the electrode changed by skilled personnel • Clean the electrode
Pump does not start and there is water in the cover	<ul style="list-style-type: none"> • Cable is damage • Cable inlet is defective • O-ring between the motor housing and cover is defective 	<ul style="list-style-type: none"> • Have the cable replaced by a skilled electrician • Have the cable inlet replaced by a skilled electrician • Change the O-ring
Pump does not start and there is water or oil in the motor housing	<ul style="list-style-type: none"> • Seal(s) defective • Sealing ring between the oil housing and motor compartment 	<ul style="list-style-type: none"> • Change the seal(s) • Change the sealing ring
There is water in the oil	<ul style="list-style-type: none"> • Seal(s) defective 	<ul style="list-style-type: none"> • Change the seal(s)

8.1

Rating Plate

The rating plate serves for the unique identification of the submersible pump. It is located at the top of the submersible pump. If you contact us by telephone in respect of queries, please have the information on the rating plate close to hand.

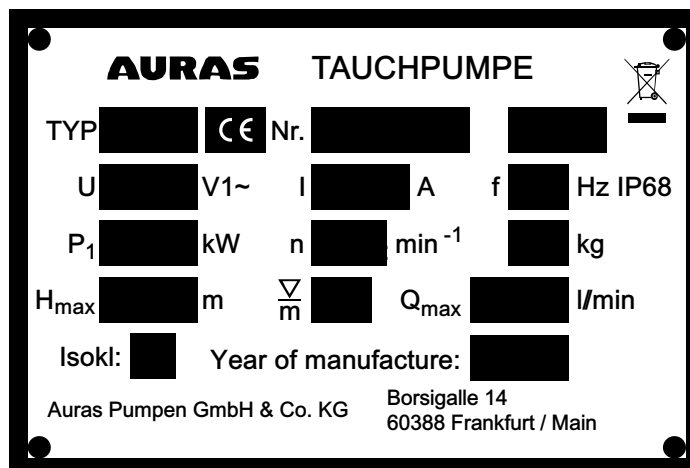

Sample rating plate (also applicable for three-phase pumps; 400V V3~)

9

Contact

If you have any queries with regard to your submersible pump, please do not hesitate to contact us. Our service team can provide all the help you need.

Auras Pumpen GmbH & Co. KG

Borsigalle 14

60388 Frankfurt / Main

Germany

Tel. +49 (0) 69 678 307-190

Fax +49 (0) 69 678 307-199

E-mail: info@auras-pumpen.de

Internet: www.tauchpumpen.de

10

Performance Curves & Technical Data

P 220/P 220 A + P 20/P 20 A Contaminated water submersible pump

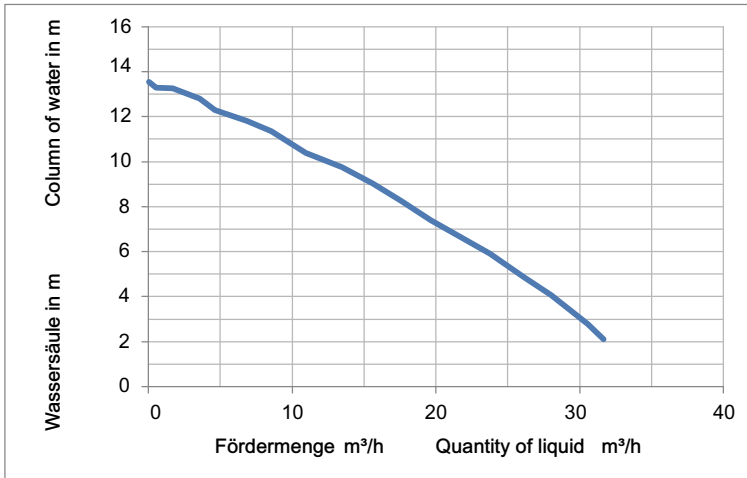

Technical Data, P 220/P 220 A

Weight	22 kg
Diameter	210 mm
Height	510 mm
Hose connection	2 inch
Impeller	Chromium-nickel steel
Wearing parts	Synthetic rubber
Nominal voltage	230 Volt
Frequency	50 Hz
Electrical fuse protection	16 A
Nominal current	6.4 A
Power input P1	1.45 kW
Cable 15 m	3 x 1.5 mm ²
Oil quantity	0.25 litre
Oil quality	Sunflower oil
Emission sound pressure level	< 70 dB (A)

Technical Data, P 20/P 20 A

Weight	23 kg
Diameter	210 mm
Height	510 mm
Hose connection	2 inch
Impeller	Chromium-nickel steel
Wearing parts	Synthetic rubber
Nominal voltage	400 Volt
Frequency	50 Hz
Electrical fuse protection	10 A
Nominal current	2.6 A
Power input P1	1.3 kW
Cable 15 m	4 x 1.5 mm ²
Oil quantity	0.25 litre
Oil quality	Sunflower oil
Emission sound pressure level	< 70 dB (A)

P 30/P 30 A Contaminated water submersible pump

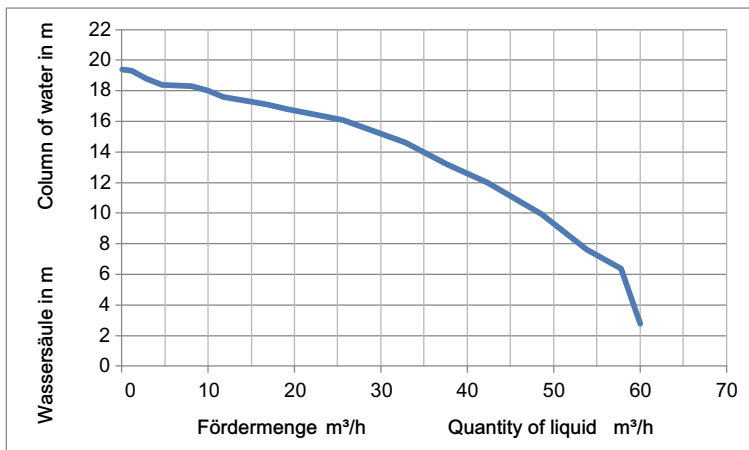

Technical Data, P 30/P 30 A

Weight	37 kg
Diameter	246 mm
Height	540 mm
Hose connection	3 inch
Impeller	Chromium-nickel steel
Wearing parts	Synthetic rubber
Nominal voltage	400 Volt
Frequency	50 Hz
Electrical fuse protection	16 A
Nominal current	5.7 A
Power input P1	3.5 kW
Cable 15 m	4 x 1.5 mm ²
Oil quantity	0.30 litre
Oil quality	Sunflower oil
Emission sound pressure level	< 70 dB (A)

The values stipulated in the curves are maximum values. Numerous factors can contribute to a reduction of the output specified when in operation (e.g. loss of friction due to the properties of the interior of the hose, etc.).

P 40 ND/P 40 ND A + P 40 HD/P 40 HD A Contaminated water submersible pump

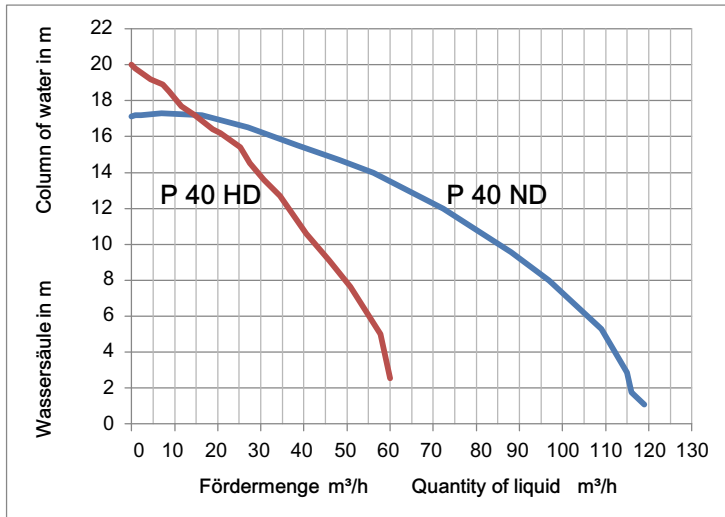

Technical Data, P 40 ND/P 40 ND A + P 40 HD/P 40 HD A

Weight	44 kg
Diameter	246 mm
Height	620 mm
Hose connection ND	4 inch
Hose connection HD	3 inch
Impeller	Chromium-nickel steel
Wearing parts	Synthetic rubber
Nominal voltage	400 Volt
Frequency	50 Hz
Electrical fuse protection	25 A
Nominal current	7.7 A
Power input P1	4.7 kW
Cable 15 m	4 x 2.5 mm ²
Oil quantity	0.30 litre
Oil quality	Sunflower oil
Emission sound pressure level	< 70 dB (A)

P 60 ND/P 60 ND A Contaminated water submersible pump

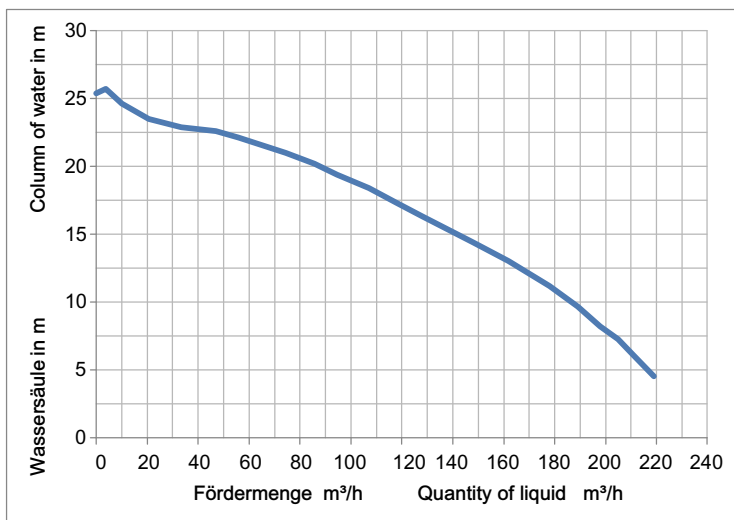

Technical Data, P 60 ND/P 60 ND A

Weight	120 kg
Diameter	350 mm
Height	910 mm
Hose connection	6 inch
Impeller	Chromium-nickel steel
Wearing parts	Synthetic rubber
Nominal voltage	400 Volt
Frequency	50 Hz
Electrical fuse protection	63 A
Nominal current	20.9 A
Power input P1	13.5 kW
Cable 15 m	4 x 6 mm ²
Oil quantity	2.50 litre
Oil quality	Sunflower oil
Emission sound pressure level	< 70 dB (A)

P 40 CS Submersible waste water pump

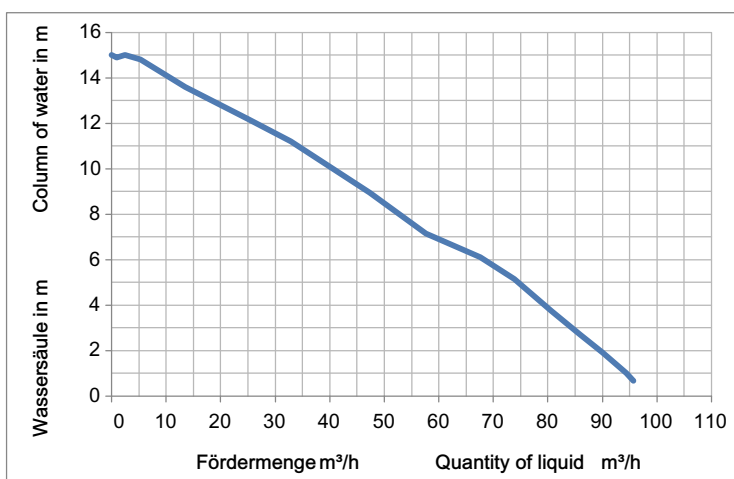

Technical Data, P 40 CS

Weight	61.5 kg
Diameter	420 mm
Height	670 mm
Hose connection	4 inch
Impeller	Chromium-nickel steel
Wearing parts	Synthetic rubber
Nominal voltage	400 Volt
Frequency	50 Hz
Electrical fuse protection	25 A
Nominal current	5.2 A
Power input P1	2.8 kW
Cable 15 m	4 x 2.5 mm ²
Oil quantity	0.50 litre
Oil quality	Sunflower oil
Emission sound pressure level	< 70 dB (A)

The values stipulated in the curves are maximum values. Numerous factors can contribute to a reduction of the output specified when in operation (e.g. loss of friction due to the properties of the interior of the hose, etc.).

11.1

Exploded Diagram, P 220 - P 220 A

- 2 — P 220/P 220 A (Automatic)
- ① — Parts for pumps without Automatic operation
- ⑦⑩ — Parts for pumps with Automatic operation

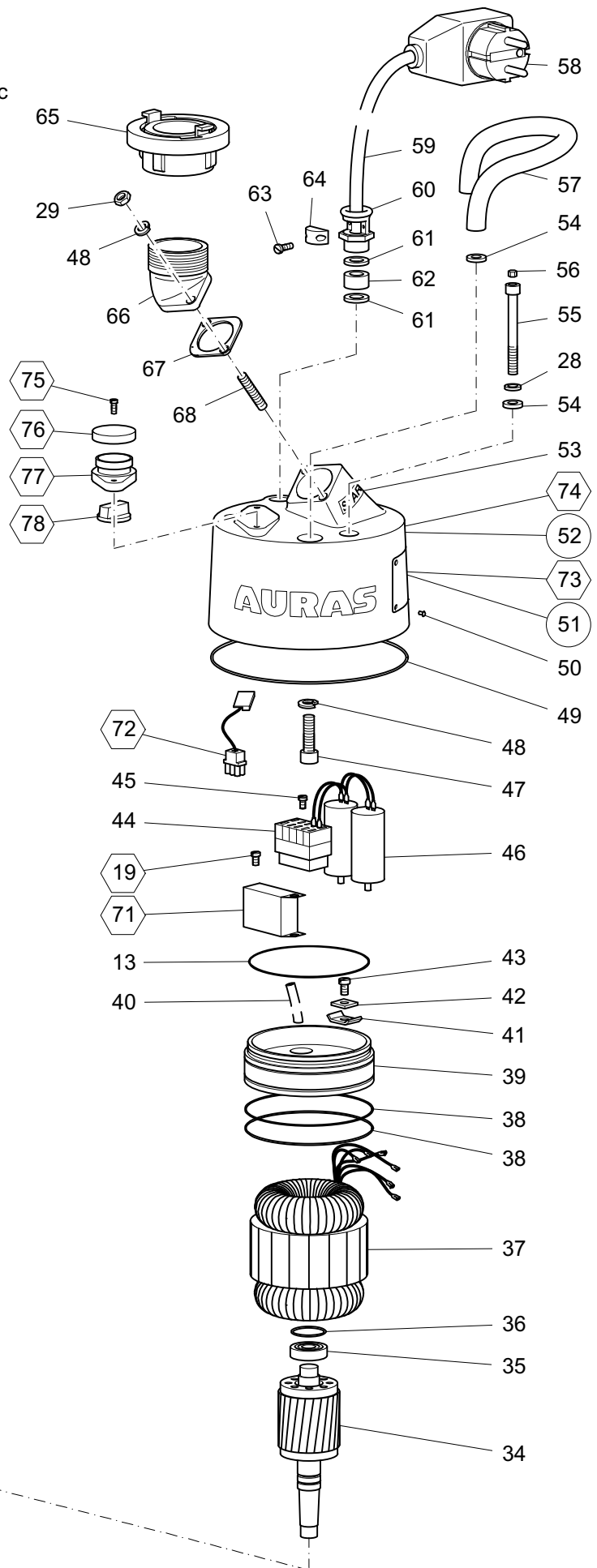
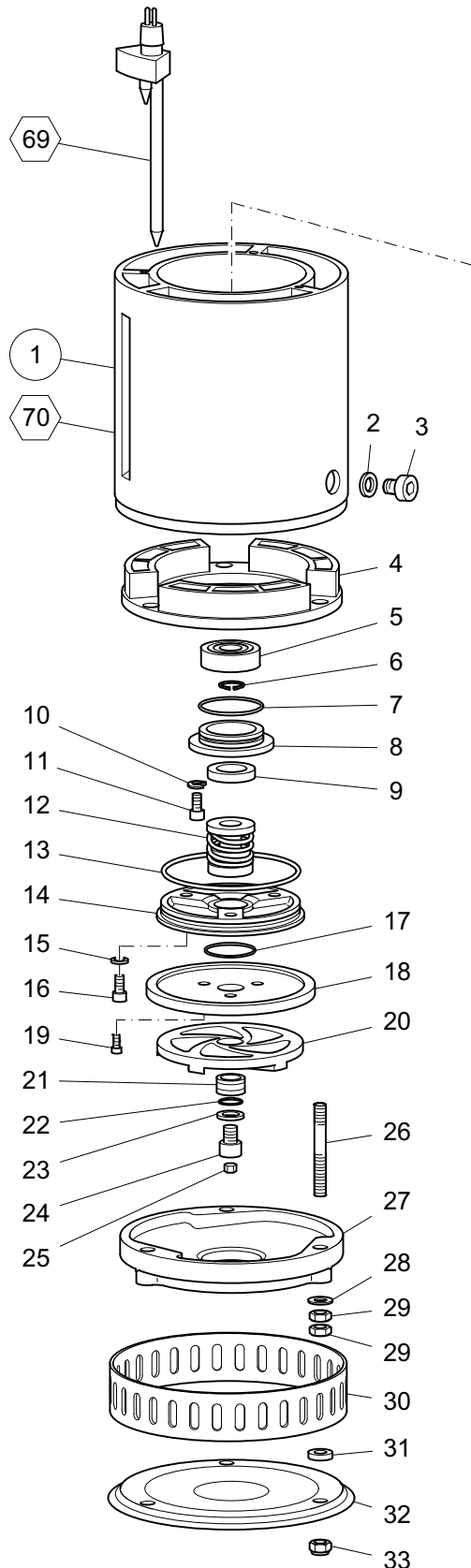

11.2 Parts List, P 220 - P 220 A

Pos.	Art. No.	Designation	Quantity	Unit
1	601003	Motor housing	1	Piece
2	601069	Dubo ring 307 M12 / 303 M8	1	Piece
3	601077	Screw DIN 6912 12 x 16 / 8 x 18	1	Piece
4	601007	Wearing lining	1	Piece
5	601042	Ball bearing 6204 2ZR	1	Piece
6	601049	Seeger ring DIN 471 A 20 x 1.2	1	Piece
7	601021	O-ring 42 x 3	1	Piece
8	601020	Seal casing	1	Piece
9	601043	Sealing ring 40 x 20 x 7	1	Piece
10	601023	Lock washer DIN 127 B5	3	Piece
11	601022	Screw DIN 912 5 x 16	3	Piece
12	601044	Sealing unit 18 mm	1	Piece
13	601064	O-ring 109 x 3	2	Piece
14	601008	Oil housing cover	1	Piece
15	601067	Dubo ring 301 M6	3	Piece
16	601085	Screw DIN 912 6 x 16	3	Piece
17	601063	O-ring 39 x 3	1	Piece
18	601009	Impeller cover	1	Piece
19	601078	Screw DIN 85 4 x 8	5	Piece
20	601011	Impeller	1	Piece
21	601050	Clamping sleeve 22 x 16 x 12	1	Piece
22	601058	O-ring 17.3 x 2.4	1	Piece
23	601071	Washer 21 x 10.5 x 4.5	1	Piece
24	601081	Screw DIN 912 10 x 16	1	Piece
25	601098	Rubber plug 9 mm	1	Piece
26	601074	Setscrew 8 x 83	3	Piece
27	601010	Diffuser	1	Piece
28	601073	Washer DIN 125 8.4	6	Piece
29	601086	Nut DIN 934 M8	8	Piece
30	601012	Sieve	1	Piece
31	601054	Rubber sleeve 17 x 8 x 2	3	Piece
32	601013	Base plate	1	Piece
33	601084	Nut DIN 985 M8	3	Piece
34	601006	Motor shaft unit	1	Piece
35	601041	Ball bearing 6202 2ZR	1	Piece
36	601059	O-ring 34 x 3	1	Piece
37	601005	Stator	1	Piece
38	601065	O-ring 120 x 3	2	Piece
39	601004	Bearing housing	1	Piece
40	603099	Protective hose Ø 10 mm	2	Piece
41	601105	Grounding washer	1	Piece
42	601101	Grounding washer	1	Piece
43	601087	Screw DIN 85 5 x 10	1	Piece

Pos.	Art. No.	Designation	Quantity	Unit
44	601142	Contactora 230 V	1	Piece
45	601143	Screw DIN 84 3 x 8	2	Piece
46	601032	Capacitor	1	Piece
47	601080	Screw DIN 912 8 x 25	2	Piece
48	601072	Lock washer DIN 127 B8	4	Piece
49	601066	O-ring 190 x 3	1	Piece
50	601088	Rivet 3 x 4	4	Piece
51	601091	Data label	1	Piece
52	601002	Cover	1	Piece
53	601093	Start direction label	1	Piece
54	601068	Dubo ring 303 M8	5	Piece
55	601082	Screw DIN 912 8 x 110	3	Piece
56	601056	Rubber plug 6 mm	3	Piece
57	601028	Mounting bracket	1	Piece
58	601001	Motor circuit breaker 8 A	1	Piece
59	601017	Motor cable 3 x 1.5	15	Metre
60	601016	Cable inlet	1	Piece
61	601019	Washer PVC 23 x 15 x 2	2	Piece
62	601018	Rubber sleeve 23 x 14 x 12	1	Piece
63	601104	Screw DIN 84 5 x 20	2	Piece
64	601103	Cable clamp	1	Piece
65	92Z3I02C	LM adapter 2"	1	Piece
66	601014	Pressure outlet 2"	1	Piece
67	601015	Gasket	1	Piece
68	601075	Setscrew 8 x 35	2	Piece
69	601132	Electrode	1	Piece
70	601130	Motor housing	1	Piece
71	601133	Switch unit 230 V	1	Piece
72	601137	Magnetic switch	1	Piece
73	601144	Data label	1	Piece
74	601131	Cover	1	Piece
75	601136	Screw DIN 84 5 x 10	2	Piece
76	601138	Rubber cap	1	Piece
77	601135	Rotary knob holder	1	Piece
78	601134	Rotary knob	1	Piece
	601110	Sunflower oil	0.25	Litre

Accessories

601113	Binding tape	2	Piece
601119	Mounting sleeve 16 mm	1	Piece
601120	Base sucker	1	Piece
601121	O ring set	1	Piece

11.3 Exploded Diagram, P 20 - P 20 A

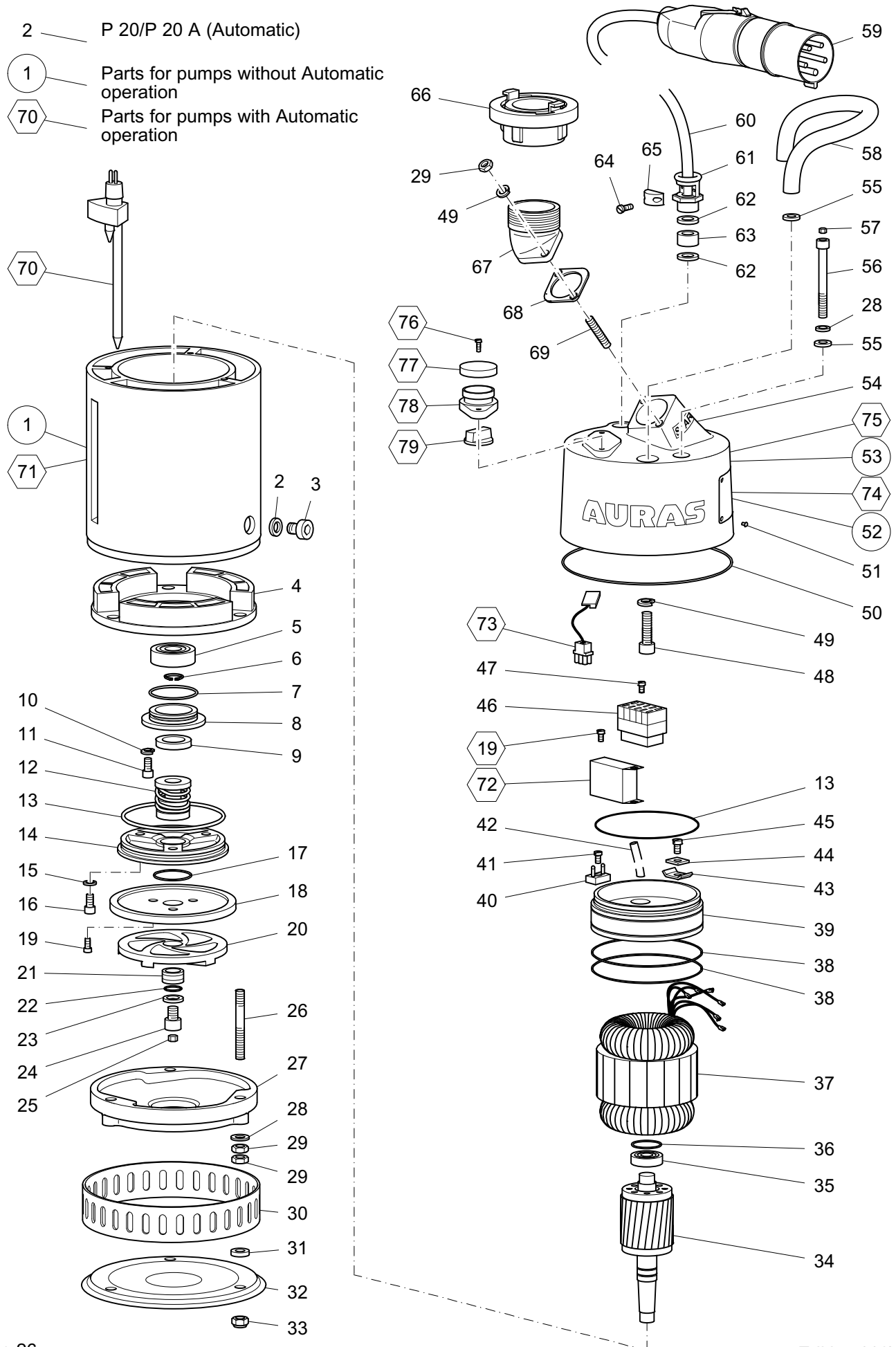

11.4 Parts List, P 20 - P 20 A

Pos.	Art. No.	Designation	Quantity	Unit
1	601003	Motor housing	1	Piece
2	601069	Dubo ring 307 M12 / 303 M8	1	Piece
3	601077	Screw DIN 6912 12 x 16 / 8 x 18	1	Piece
4	601007	Wearing lining	1	Piece
5	601042	Ball bearing 6204 2ZR	1	Piece
6	601049	Seeger ring DIN 471 A 20 x 1.2	1	Piece
7	601021	O-ring 42 x 3	1	Piece
8	601020	Seal casing	1	Piece
9	601043	Sealing ring 40 x 20 x 7	1	Piece
10	601023	Lock washer DIN 127 B5	3	Piece
11	601022	Screw DIN 912 5 x 16	3	Piece
12	601044	Sealing unit 18 mm	1	Piece
13	601064	O-ring 109 x 3	2	Piece
14	601008	Oil housing cover	1	Piece
15	601067	Dubo ring 301 M6	3	Piece
16	601085	Screw DIN 912 6 x 16	3	Piece
17	601063	O-ring 39 x 3	1	Piece
18	601009	Impeller cover	1	Piece
19	601078	Screw DIN 85 4 x 8	5	Piece
20	601011	Impeller	1	Piece
21	601050	Clamping sleeve 22 x 16 x 12	1	Piece
22	601058	O-ring 17.3 x 2.4	1	Piece
23	601071	Washer 21 x 10.5 x 4.5	1	Piece
24	601081	Screw DIN 912 10 x 16	1	Piece
25	601098	Rubber plug 9 mm	1	Piece
26	601074	Setscrew 8 x 83	3	Piece
27	601010	Diffuser	1	Piece
28	601073	Washer DIN 125 8.4	6	Piece
29	601086	Nut DIN 934 M8	8	Piece
30	601012	Sieve	1	Piece
31	601054	Rubber sleeve 17 x 8 x 2	3	Piece
32	601013	Base plate	1	Piece
33	601084	Nut DIN 985 M8	3	Piece
34	602006	Motor shaft unit	1	Piece
35	601041	Ball bearing 6202 2ZR	1	Piece
36	601059	O-ring 34 x 3	1	Piece
37	602005	Stator	1	Piece
38	601065	O-ring 120 x 3	2	Piece
39	601004	Bearing housing	1	Piece
40	602034	Switchboard	1	Piece
41	601076	Screw DIN 84 4 x 12	1	Piece
42	603099	Protective hose Ø 10 mm	2	Piece
43	601105	Grounding washer	1	Piece

Pos.	Art. No.	Designation	Quantity	Unit
44	601101	Grounding washer	1	Piece
45	601087	Screw DIN 85 5 x 10	1	Piece
46	602033	Air-break contactor 400 V	1	Piece
47	601143	Screw DIN 84 3 x 8	2	Piece
48	601080	Screw DIN 912 8 x 25	2	Piece
49	601072	Lock washer DIN 127 B8	4	Piece
50	601066	O-ring 190 x 3	1	Piece
51	601088	Rivet 3 x 4	4	Piece
52	602091	Data label	1	Piece
53	601002	Cover	1	Piece
54	601093	Start direction label	1	Piece
55	601068	Dubo ring 303 M8	5	Piece
56	601082	Screw DIN 912 8 x 110	3	Piece
57	601056	Rubber plug 6 mm	3	Piece
58	601028	Mounting bracket	1	Piece
59	602001	Reversing switch 16 A	1	Piece
60	602017	Motor cable 4 x 1.5	15	Metre
61	601016	Cable inlet	1	Piece
62	601019	Washer PVC 23 x 15 x 2	2	Piece
63	601018	Rubber sleeve 23 x 14 x 12	1	Piece
64	601104	Screw DIN 84 5 x 20	2	Piece
65	601103	Cable clamp	1	Piece
66	92Z3I02C	LM adapter 2"	1	Piece
67	601014	Pressure outlet 2"	1	Piece
68	601015	Gasket	1	Piece
69	601075	Setscrew 8 x 35	2	Piece
70	601132	Electrode	1	Piece
71	601130	Motor housing	1	Piece
72	602133	Switch unit 400 V	1	Piece
73	601137	Magnetic switch	1	Piece
74	602144	Data label	1	Piece
75	601131	Cover	1	Piece
76	601136	Screw DIN 84 5 x 10	2	Piece
77	601138	Rubber cap	1	Piece
78	601135	Rotary knob holder	1	Piece
79	601134	Rotary knob	1	Piece
	601110	Sunflower oil	0.25	Litre

Accessories

601113	Binding tape	2	Piece
601119	Mounting sleeve 16 mm	1	Piece
601120	Base sucker	1	Piece
601121	O ring set	1	Piece

11.5 Exploded Diagram, P 30 - P 30 A

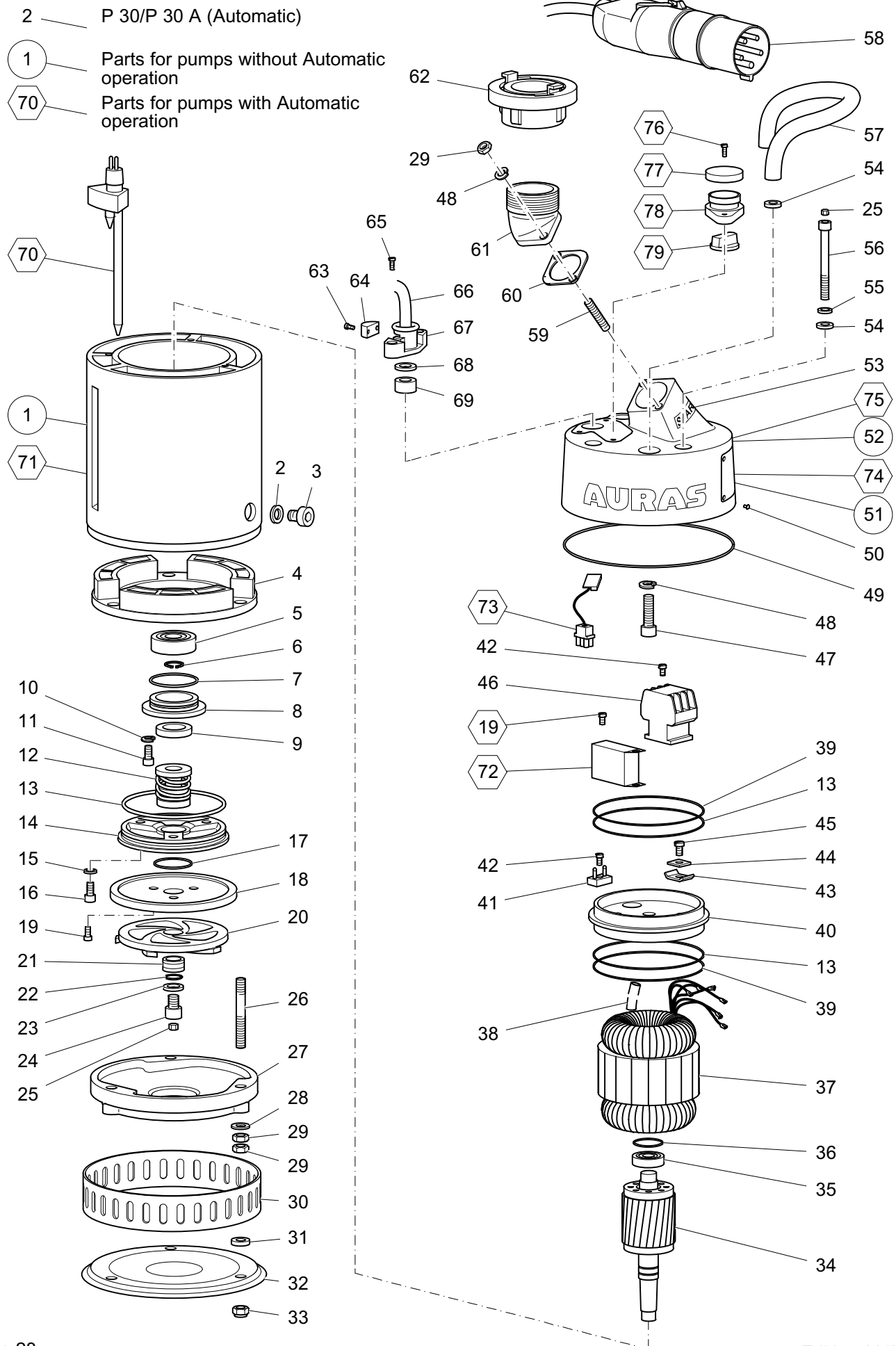

11.6 Parts List, P 30 - P 30 A

Pos.	Art. No.	Designation	Quantity	Unit	Pos.	Art. No.	Designation	Quantity	Unit
1	603003	Motor housing	1	Piece	44	601101	Grounding washer	1	Piece
2	601069	Dubo ring 307 M12 / 303 M8	1	Piece	45	601087	Screw DIN 85 5 x 10	1	Piece
3	601077	Screw DIN 6912 12 x 16 / 8 x 18	1	Piece	46	603063	Air-break contactor 400 V	1	Piece
4	603020	Wearing lining	1	Piece	47	603080	Screw DIN 912 10 x 40	2	Piece
5	601042	Ball bearing 6204 2ZR	1	Piece	48	603072	Lock washer DIN 127 B10	4	Piece
6	601049	Seeger ring DIN 471 A 20 x 1.2	1	Piece	49	603029	O-ring 220 x 3	1	Piece
7	601021	O-ring 42 x 3	1	Piece	50	601088	Rivet 3 x 4	4	Piece
8	601020	Seal casing	1	Piece	51	603084	Data label	1	Piece
9	601043	Sealing ring 40 x 20 x 7	1	Piece	52	603004	Cover	1	Piece
10	601023	Lock washer DIN 127 B5	3	Piece	53	601093	Start direction label	1	Piece
11	601022	Screw DIN 912 5 x 16	3	Piece	54	603055	Dubo ring 305 M10	5	Piece
12	601044	Sealing unit 18 mm	1	Piece	55	603049	Washer DIN 433 10.5	3	Piece
13	603030	O-ring 134.5 x 3	3	Piece	56	603043	Screw DIN 912 10 x 90	3	Piece
14	603016	Oil housing cover	1	Piece	57	603002	Mounting bracket	1	Piece
15	601068	Dubo ring 303 M8	3	Piece	58	602001	Reversing switch 16 A	1	Piece
16	601080	Screw DIN 912 8 x 25	3	Piece	59	603042	Setscrew 10 x 43	2	Piece
17	601063	O-ring 39 x 3	1	Piece	60	603040	Gasket	1	Piece
18	603012	Impeller cover	1	Piece	61	603005	Pressure outlet 2.5"	1	Piece
19	601078	Screw DIN 85 4 x 8	5	Piece	62	92Z3I02B	LM adapter 3"	1	Piece
20	603015	Impeller	1	Piece	63	603052	Screw DIN 84 6 x 25	2	Piece
21	603059	Clamping sleeve	1	Piece	64	603007	Cable clamp	1	Piece
22	601058	O-ring 17.3 x 2.4	1	Piece	65	603045	Screw DIN 912 8 x 18	2	Piece
23	601071	Washer 21 x 10.5 x 4.5	1	Piece	66	602017	Motor cable 4 x 1.5	15	Metre
24	601081	Screw DIN 912 10 x 16	1	Piece	67	603006	Cable inlet	1	Piece
25	601098	Rubber plug 9 mm	4	Piece	68	603101	Washer PVC 25 x 17 x 2	1	Piece
26	603041	Setscrew 10 x 110	3	Piece	69	603024	Rubber sleeve 25 x 14.5 x 9.5	1	Piece
27	603019	Diffuser	1	Piece	70	603132	Electrode	1	Piece
28	603054	Washer DIN 125 10.5	3	Piece	71	603130	Motor housing	1	Piece
29	603053	Nut DIN 934 M10	8	Piece	72	603133	Switch unit 400 V	1	Piece
30	603014	Sieve	1	Piece	73	601137	Magnetic switch	1	Piece
31	603023	Rubber sleeve 16 x 10 x 5	9	Piece	74	603144	Data label	1	Piece
32	603013	Base plate	1	Piece	75	603131	Cover	1	Piece
33	603078	Nut DIN 985 M10	3	Piece	76	601136	Screw DIN 84 5 x 10	2	Piece
34	603017	Motor shaft unit	1	Piece	77	601138	Rubber cap	1	Piece
35	601041	Ball bearing 6202 2ZR	1	Piece	78	601135	Rotary knob holder	1	Piece
36	601059	O-ring 34 x 3	1	Piece	79	601134	Rotary knob	1	Piece
37	603018	Stator	1	Piece		601110	Sunflower oil	0.3	Litre
38	603099	Protective hose Ø 10 mm	2	Piece			Accessories		
39	603089	O-ring 139.5 x 3	2	Piece		601113	Binding tape	2	Piece
40	603010	Bearing housing	1	Piece		601119	Mounting sleeve 16 mm	1	Piece
41	602034	Switchboard	1	Piece		603121	O ring set	1	Piece
42	601076	Screw DIN 84 4 x 12	3	Piece					
43	601105	Grounding washer	1	Piece					

11.7

Exploded Diagram, P 40 ND - P 40 ND A

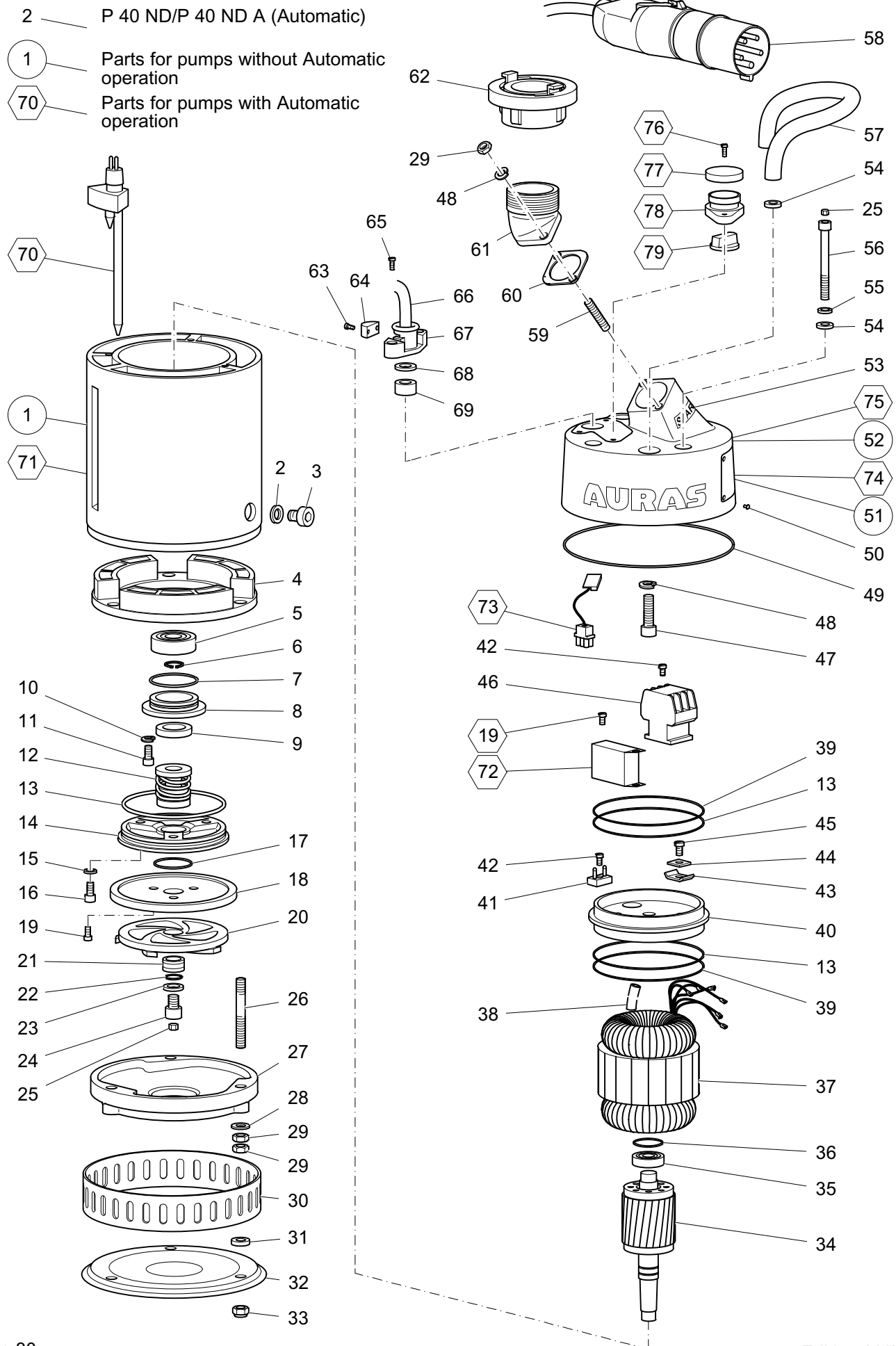

11.8 Parts List, P 40 ND - P 40 ND A

Pos.	Art. No.	Designation	Quantity	Unit	Pos.	Art. No.	Designation	Quantity	Unit
1	604003	Motor housing	1	Piece	44	601101	Grounding washer	1	Piece
2	601069	Dubo ring 307 M12 / 303 M8	1	Piece	45	601087	Screw DIN 85 5 x 10	1	Piece
3	601077	Screw DIN 6912 12 x 16 / 8 x 18	1	Piece	46	603063	Air-break contactor 400 V	1	Piece
4	603020	Wearing lining	1	Piece	47	603080	Screw DIN 912 10 x 40	2	Piece
5	601042	Ball bearing 6204 2ZR	1	Piece	48	603072	Lock washer DIN 127 B10	4	Piece
6	601049	Seeger ring DIN 471 A 20 x 1.2	1	Piece	49	603029	O-ring 220 x 3	1	Piece
7	601021	O-ring 42 x 3	1	Piece	50	601088	Rivet 3 x 4	4	Piece
8	601020	Seal casing	1	Piece	51	604084	Data label	1	Piece
9	601043	Sealing ring 40 x 20 x 7	1	Piece	52	603004	Cover	1	Piece
10	601023	Lock washer DIN 127 B5	3	Piece	53	601093	Start direction label	1	Piece
11	601022	Screw DIN 912 5 x 16	3	Piece	54	603055	Dubo ring 305 M10	5	Piece
12	601044	Sealing unit 18 mm	1	Piece	55	603049	Washer DIN 433 10.5	3	Piece
13	603030	O-ring 134.5 x 3	3	Piece	56	603043	Screw DIN 912 10 x 90	3	Piece
14	603016	Oil housing cover	1	Piece	57	603002	Mounting bracket	1	Piece
15	601068	Dubo ring 303 M8	3	Piece	58	604001	Reversing switch 32 A	1	Piece
16	601080	Screw DIN 912 8 x 25	3	Piece	59	603042	Setscrew 10 x 43	2	Piece
17	601063	O-ring 39 x 3	1	Piece	60	603040	Gasket	1	Piece
18	603012	Impeller cover	1	Piece	61	604005	Pressure outlet 4"	1	Piece
19	601078	Screw DIN 85 4 x 8	5	Piece	62	92Z3I04A	LM adapter 4"	1	Piece
20	604015	Impeller	1	Piece	63	603052	Screw DIN 84 6 x 25	2	Piece
21	603059	Clamping sleeve 22 x 16 x 19	1	Piece	64	603007	Cable clamp	1	Piece
22	601058	O-ring 17.3 x 2.4	1	Piece	65	603045	Screw DIN 912 8 x 18	2	Piece
23	601071	Washer 21 x 10.5 x 4.5	1	Piece	66	604066	Motor cable 4 x 2.5	15	Metre
24	601081	Screw DIN 912 10 x 16	1	Piece	67	603006	Cable inlet	1	Piece
25	601098	Rubber plug 9 mm	4	Piece	68	603101	Washer PVC 25 x 17 x 2	1	Piece
26	603041	Setscrew 10 x 110	3	Piece	69	604024	Rubber sleeve 25 x 17 x 9.5	1	Piece
27	604019	Diffuser	1	Piece	70	603132	Electrode	1	Piece
28	603054	Washer DIN 125 10.5	3	Piece	71	604130	Motor housing	1	Piece
29	603053	Nut DIN 934 M10	8	Piece	72	603133	Switch unit 400 V	1	Piece
30	603014	Sieve	1	Piece	73	601137	Magnetic switch	1	Piece
31	603023	Rubber sleeve 16 x 10 x 5	6	Piece	74	604144	Data label	1	Piece
32	603013	Base plate	1	Piece	75	603131	Cover	1	Piece
33	603078	Nut DIN 985 M10	3	Piece	76	601136	Screw DIN 84 5 x 10	2	Piece
34	604017	Motor shaft unit	1	Piece	77	601138	Rubber cap	1	Piece
35	601041	Ball bearing 6202 2ZR	1	Piece	78	601135	Rotary knob holder	1	Piece
36	601059	O-ring 34 x 3	1	Piece	79	601134	Rotary knob	1	Piece
37	604018	Stator	1	Piece		601110	Sunflower oil	0.3	Litre
38	603099	Protective hose Ø 10 mm	2	Piece	Accessories				
39	603089	O-ring 139.5 x 3	2	Piece		601113	Binding tape	2	Piece
40	604010	Bearing housing	1	Piece		601119	Mounting sleeve 16 mm	1	Piece
41	602034	Switchboard	1	Piece		603121	O ring set	1	Piece
42	601076	Screw	3	Piece					
43	601105	Grounding washer	1	Piece					

11.9 Exploded Diagram, P 40 HD - P 40 HD A

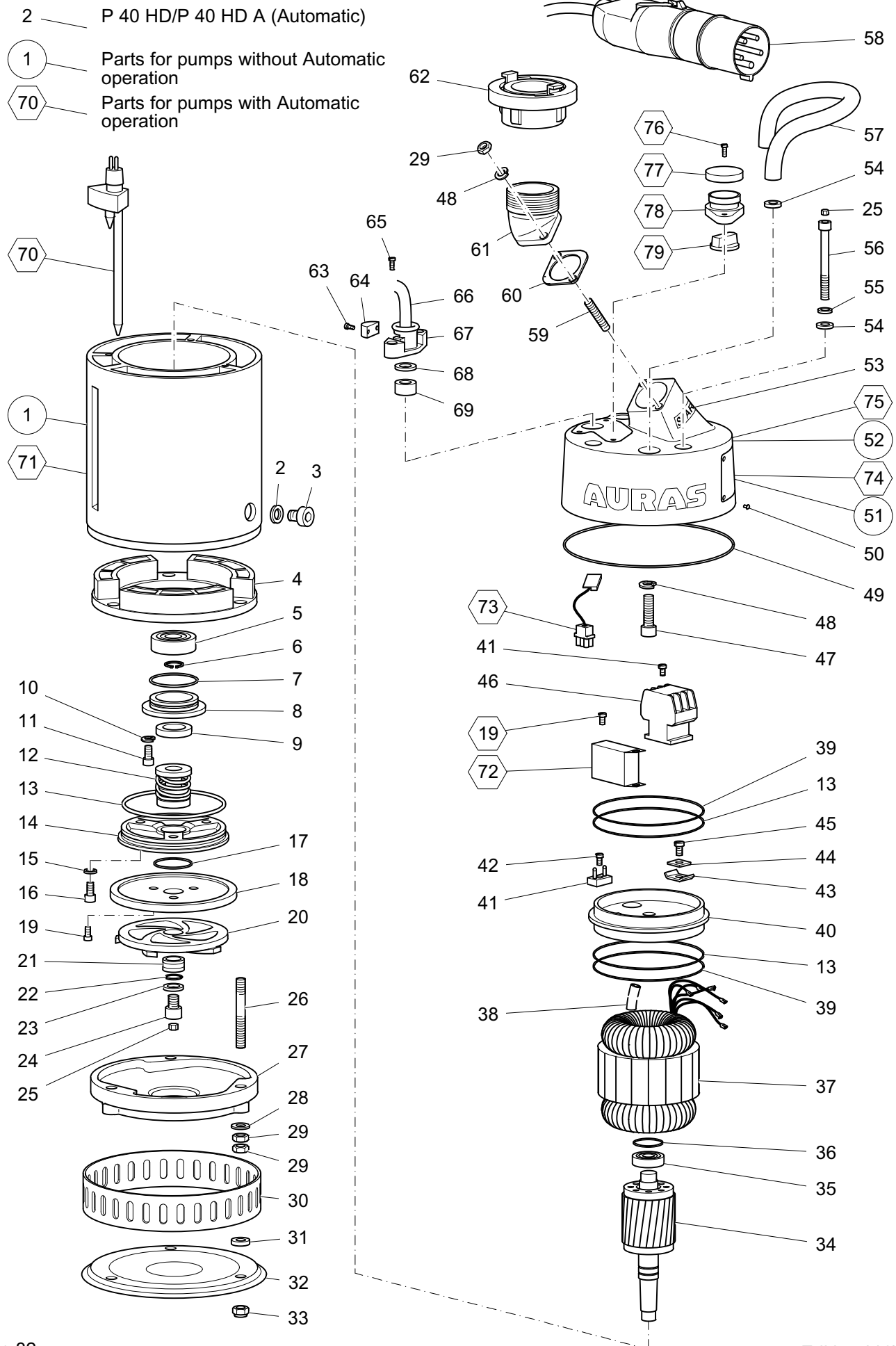

11.10 Parts List, P 40 HD - P 40 HD A

Pos.	Art. No.	Designation	Quantity	Unit	Pos.	Art. No.	Designation	Quantity	Unit
1	604003	Motor housing	1	Piece	44	601101	Grounding washer	1	Piece
2	601069	Dubo ring 307 M12 / 303 M8	1	Piece	45	601087	Screw DIN 85 5 x 10	1	Piece
3	601077	Screw DIN 6912 12 x 16 / 8 x 18	1	Piece	46	603063	Air-break contactor 400 V	1	Piece
4	603020	Wearing lining	1	Piece	47	603080	Screw DIN 912 10 x 40	2	Piece
5	601042	Ball bearing 6204 2ZR	1	Piece	48	603072	Lock washer DIN 127 B10	4	Piece
6	601049	Seeger ring DIN 471 A 20 x 1.2	1	Piece	49	603029	O-ring 220 x 3	1	Piece
7	601021	O-ring 42 x 3	1	Piece	50	601088	Rivet 3 x 4	4	Piece
8	601020	Seal casing	1	Piece	51	614084	Data label	1	Piece
9	601043	Sealing ring 40 x 20 x 7	1	Piece	52	603004	Cover	1	Piece
10	601023	Lock washer DIN 127 B5	3	Piece	53	601093	Start direction label	1	Piece
11	601022	Screw DIN 912 5 x 16	3	Piece	54	603055	Dubo ring 305 M10	5	Piece
12	601044	Sealing unit 18 mm	1	Piece	55	603049	Washer DIN 433 10.5	3	Piece
13	603030	O-ring 134.5 x 3	3	Piece	56	603043	Screw DIN 912 10 x 90	3	Piece
14	603016	Oil housing cover	1	Piece	57	603002	Mounting bracket	1	Piece
15	601068	Dubo ring 303 M8	3	Piece	58	604001	Reversing switch 32 A	1	Piece
16	601080	Screw DIN 912 8 x 25	3	Piece	59	603042	Setscrew 10 x 43	2	Piece
17	601063	O-ring 39 x 3	1	Piece	60	603040	Gasket	1	Piece
18	603012	Impeller cover	1	Piece	61	603005	Pressure outlet 2.5"	1	Piece
19	601078	Screw DIN 85 4 x 8	5	Piece	62	92Z3I02B	LM adapter 3"	1	Piece
20	604114	Impeller	1	Piece	63	603052	Screw DIN 84 6 x 25	2	Piece
21	603059	Clamping sleeve 22 x 16 x 19	1	Piece	64	603007	Cable clamp	1	Piece
22	601058	O-ring 17.3 x 2.4	1	Piece	65	603045	Screw DIN 912 8 x 18	2	Piece
23	601071	Washer 21 x 10.5 x 4.5	1	Piece	66	604066	Motor cable 4 x 2.5	15	Metre
24	601081	Screw DIN 912 10 x 16	1	Piece	67	603006	Cable inlet	1	Piece
25	601098	Rubber plug 9 mm	4	Piece	68	603101	Washer PVC 25 x 17 x 2	1	Piece
26	603041	Setscrew 10 x 110	3	Piece	69	604024	Rubber sleeve 25 x 17 x 9.5	1	Piece
27	604019	Diffuser	1	Piece	70	603132	Electrode	1	Piece
28	603054	Washer DIN 125 10.5	3	Piece	71	604130	Motor housing	1	Piece
29	603053	Nut DIN 934 M10	8	Piece	72	603133	Switch unit 400 V	1	Piece
30	603014	Sieve	1	Piece	73	601137	Magnetic switch	1	Piece
31	603023	Rubber sleeve 16 x 10 x 5	6	Piece	74	614144	Data label	1	Piece
32	603013	Base plate	1	Piece	75	603131	Cover	1	Piece
33	603078	Nut DIN 985 M10	3	Piece	76	601136	Screw DIN 84 5 x 10	2	Piece
34	604017	Motor shaft unit	1	Piece	77	601138	Rubber cap	1	Piece
35	601041	Ball bearing 6202 2ZR	1	Piece	78	601135	Rotary knob holder	1	Piece
36	601059	O-ring 34 x 3	1	Piece	79	601134	Rotary knob	1	Piece
37	604018	Stator	1	Piece		601110	Sunflower oil	0.3	Litre
38	603099	Protective hose Ø 10 mm	2	Piece		Accessories			
39	603089	O-ring 139.5 x 3	2	Piece		601113	Binding tape	2	Piece
40	604010	Bearing housing	1	Piece		601119	Mounting sleeve 16 mm	1	Piece
41	602034	Switchboard	1	Piece		603121	O ring set	1	Piece
42	601076	Screw	3	Piece					
43	601105	Grounding washer	1	Piece					

11.11

Exploded Diagram, P 60 ND - P 60 ND A

- 2 — P 60 ND/P 60 ND A (Automatic)
- 1 — Parts for pumps without Automatic operation
- 76 — Parts for pumps with Automatic operation

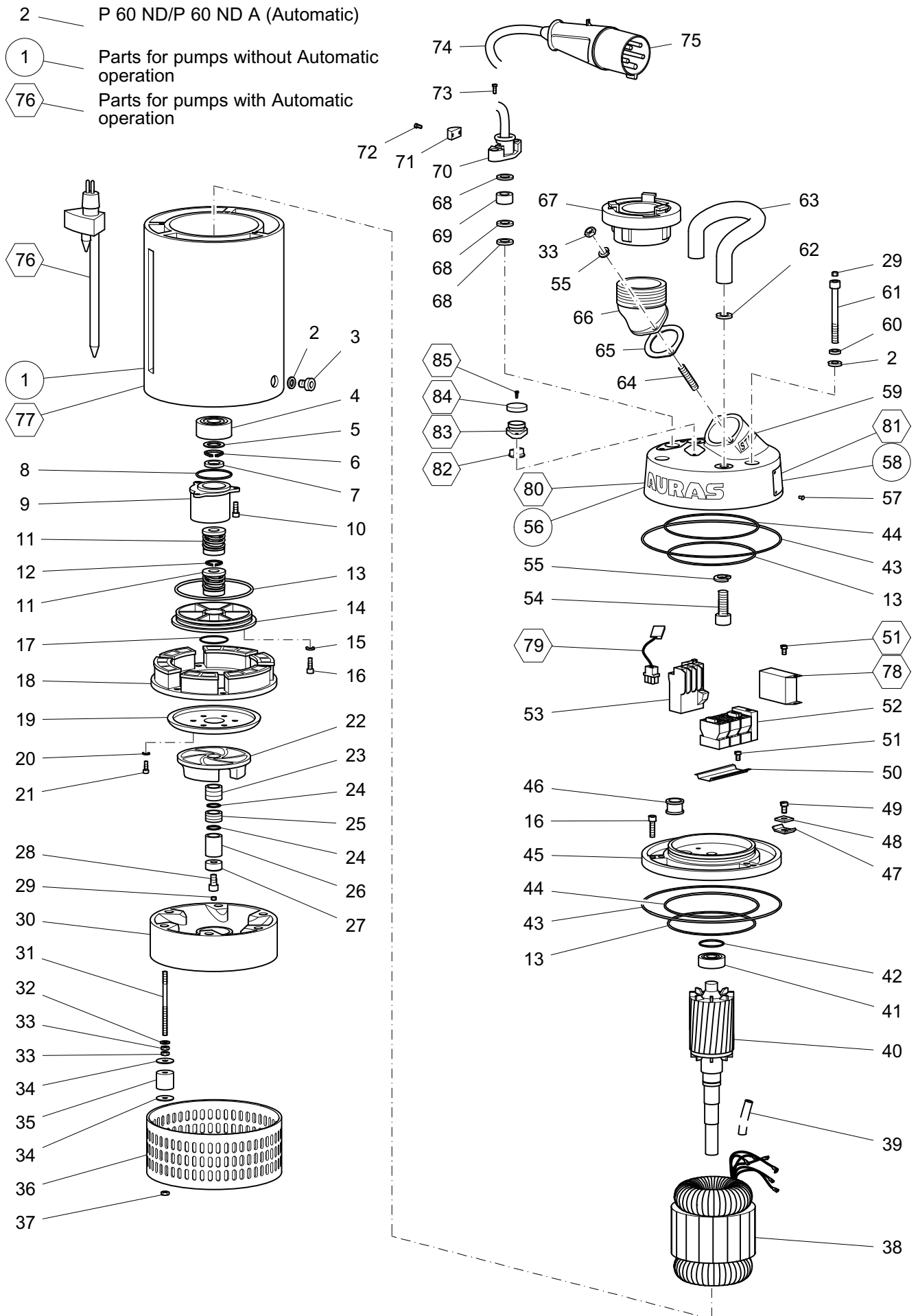

11.12 Parts List, P 60 ND - P 60 ND A

Pos.	Art. No.	Designation	Quantity	Unit	Pos.	Art. No.	Designation	Quantity	Unit
1	605003	Motor housing	1	Piece	47	601105	Grounding washer	1	Piece
2	601069	Dubo ring 307 M12	5	Piece	48	601101	Grounding washer	1	Piece
3	601077	Screw DIN 6912 12 x 16	2	Piece	49	601087	Screw DIN 85 5 x 10	1	Piece
4	605038	Ball bearing 3308 B	1	Piece	50	605064	Fastening rail	1	Piece
5	605074	Washer 50 x 41 x 2.5	1	Piece	51	601078	Screw DIN 85 4 x 8	2	Piece
6	605060	Seeger ring DIN 471 40 x 1.8	1	Piece	52	605063	Star-delta switching	1	Piece
7	605112	Sealing ring 40 x 47 x 4	1	Piece	53	605092	Overload relay	1	Piece
8	605031	O-ring 89.2 x 5.7	1	Piece	54	/FAPBT6 05002-1	Screw	2	Piece
9	605011	Bearing housing	1	Piece	55	605070	Lock washer DIN 127 B12	4	Piece
10	601080	Screw DIN 912 8 x 25	3	Piece	56	605004	Cover	1	Piece
11	605067	Sealing unit 32 mm	2	Piece	57	601088	Rivet 3 x 4	4	Piece
12	605113	Seeger ring DIN 471 32 x 1.5	1	Piece	58	605084	Data label	1	Piece
13	605030	O-ring 199.2 x 5.7	3	Piece	59	601093	Start direction label	1	Piece
14	605016	Oil housing cover	1	Piece	60	605050	Washer DIN 433 12.5	2	Piece
15	601068	Dubo ring 303 M8	3	Piece	61	605043	Screw DIN 912 12 x 140	3	Piece
16	605044	Screw DIN 912 8 x 30	6	Piece	62	601019	Washer PVC 23 x 15 x 2	2	Piece
17	605028	O-ring 64 x 3	1	Piece	63	605002	Mounting bracket	1	Piece
18	605020	Wearing lining	1	Piece	64	605042	Setscrew 12 x 50	2	Piece
19	605012	Impeller cover	1	Piece	65	605040	Gasket	1	Piece
20	605080	Washer DIN 125 4.3	6	Piece	66	605005	Pressure outlet 6"	1	Piece
21	601076	Screw DIN 84 4 x 12	6	Piece	67	92Z3106F	LM adapter 6"	1	Piece
22	605015	Impeller	1	Piece	68	605101	Washer PVC 35 x 22 x 2	3	Piece
23	605059	Clamping sleeve 40 x 28 x 26v	1	Piece	69	605024	Rubber sleeve 35 x 20 x 21	1	Piece
24	601059	O-ring 34 x 3	5	Piece	70	605006	Cable inlet	1	Piece
25	605072	Clamping sleeve 40 x 28 x 16	1	Piece	71	605007	Cable clamp	1	Piece
26	605083	Sleeve 39.8 x 28.1 x 55	1	Piece	72	603052	Screw DIN 84 6 x 25	2	Piece
27	605071	Washer 40 x 13 x 20	1	Piece	73	601080	Screw DIN 912 8 x 25	2	Piece
28	605077	Screw DIN 912 12 x 25	1	Piece	74	605066	Motor cable 4 x 6	15	Metre
29	605075	Rubber plug 10 mm	4	Piece	75	605001	Connector	1	Piece
30	605019	Diffuser	1	Piece	76	605132	Electrode	1	Piece
31	605041	Setscrew 12 x 210	6	Piece	77	605130	Motor housing	1	Piece
32	605054	Washer DIN 125 12.5	6	Piece	78	603133	Switch unit 40 V	1	Piece
33	605053	Nut DIN 934 M12	14	Piece	79	601137	Magnetic switch	1	Piece
34	605108	Washer DIN 9021 M14	12	Piece	80	605131	Cover	1	Piece
35	605107	Spacer sleeve 41.5 x 15 x 56	6	Piece	81	605144	Data label	1	Piece
36	605014	Sieve	1	Piece	82	601134	Rotary knob	1	Piece
37	605023	Nut DIN 985 M12	6	Piece	83	605135	Rotary knob holder	1	Piece
38	605018	Stator	1	Piece	84	601138	Rubber cap	1	Piece
39	603099	Protective hose Ø 10 mm	2	Piece	85	601136	Screw DIN 84 5 x 10	2	Piece
40	605017	Motor shaft unit	1	Piece		601110	Sunflower oil	2.5	Litre
41	605039	Ball bearing 6206 2ZR	1	Piece					
42	605032	O-ring 62.2 x 5.7	1	Piece					
43	605029	O-ring 340 x 4	2	Piece					
44	603029	O-ring 220 x 3	2	Piece					
45	605010	Spacer	1	Piece					
46	605088	Rubber sleeve	1	Piece					
							Accessories		
						601113	Binding tape	2	Piece
						605119	Mounting sleeve 32 mm	1	Piece
						605121	O ring set	1	Piece

11.13 Exploded Diagram, P 40 CS

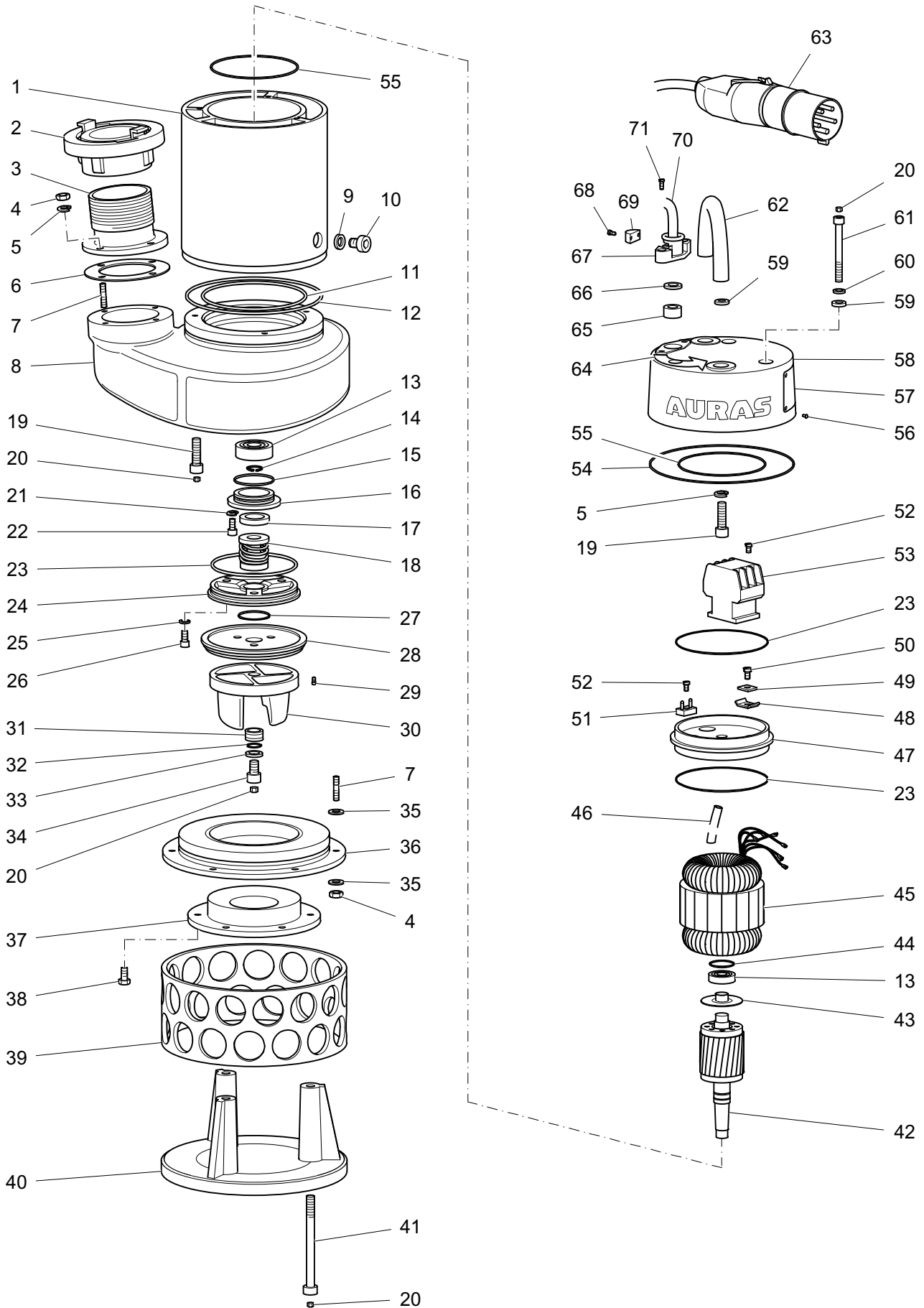

11.14 Parts List, P 40 CS

Pos.	Art. No.	Designation	Quantity	Unit
1	604003	Motor housing	1	Piece
2	92Z3I04A	LM adapter 4"	1	Piece
3	606005	Pressure outlet 4"	1	Piece
4	603053	Nut DIN 934 M10	10	Piece
5	603072	Lock washer DIN 127 B10	6	Piece
6	606040	Gasket	1	Piece
7	603042	Setscrew 10 x 43	10	Piece
8	606096	Pump housing	1	Piece
9	601069	Dubo ring 307 M12 / 303 M8	1	Piece
10	601077	Screw DIN 6912 12 x 16 / 8 x 18	1	Piece
11	606108	O-ring 147.5 x 3	1	Piece
12	606109	O-ring 210 x 3	1	Piece
13	601042	Ball bearing 6204 2ZR	2	Piece
14	601049	Seeger ring DIN 471 20 x 1.2	1	Piece
15	601021	O-ring 42 x 3	1	Piece
16	601020	Seal casing	1	Piece
17	601043	Sealing ring 40 x 20 x 7	1	Piece
18	601044	Sealing unit 18 mm	1	Piece
19	603080	Screw DIN 912 10 x 40	5	Piece
20	601098	Rubber plug 9 mm	10	Piece
21	601023	Lock washer DIN 127 B5	3	Piece
22	601022	Screw DIN 912 5 x 16	3	Piece
23	603030	O-ring 134.5 x 3	3	Piece
24	603016	Oil housing cover	1	Piece
25	601068	Dubo ring 303 M8	3	Piece
26	601080	Screw DIN 912 8 x 25	3	Piece
27	601063	O-ring 39 x 3	1	Piece
28	603012	Impeller cover	1	Piece
29	601078	Screw DIN 85 4 x 8	3	Piece
30	606015	Impeller	1	Piece
31	603059	Clamping sleeve 22 x 16 x 19	1	Piece
32	601058	O-ring 17.3 x 2.4	1	Piece
33	601071	Washer 21 x 10.5 x 4.5	1	Piece
34	601081	Screw DIN 912 10 x 16	1	Piece
35	603054	Washer DIN 125 10.5	12	Piece
36	606020	Wearing lining	1	Piece
37	606019	Wearing plate	1	Piece
38	606118	Screw DIN 933 10 x 20	3	Piece
39	606014	Sieve	1	Piece
40	606013	Foot	1	Piece

Pos.	Art. No.	Designation	Quantity	Unit
41	606050	Screw DIN 912 10 x 140	3	Piece
42	604017	Motor shaft unit	1	Piece
43	606106	Bearing bush	1	Piece
44	606032	O-ring 47 x 3	1	Piece
45	604018	Stator	1	Piece
46	603099	Protective hose Ø 10 mm	2	Piece
47	606010	Bearing housing	1	Piece
48	601105	Grounding washer	1	Piece
49	601101	Grounding washer	1	Piece
50	601087	Screw DIN 85 5 x 10	1	Piece
51	602034	Switchboard	1	Piece
52	601076	Screw DIN 84 4 x 12	3	Piece
53	603063	Air-break contactor 400 V	1	Piece
54	603029	O-ring 220 x 3	1	Piece
55	603089	O-ring 139.5 x 3	2	Piece
56	601088	Rivet 3 x 4	4	Piece
57	606084	Data label	1	Piece
58	606004	Cover	1	Piece
59	603055	Dubo ring 305 M10	5	Piece
60	603049	Washer	3	Piece
61	603043	Screw	3	Piece
62	606002	Mounting bracket	1	Piece
63	604001	Reversing switch	1	Piece
64	601093	Start label	1	Piece
65	604024	Rubber sleeve	1	Piece
66	603101	Washer	1	Piece
67	603006	Cable inlet	1	Piece
68	603052	Screw	2	Piece
69	603007	Cable clamp	1	Piece
70	604066	Motor cable	15	Metre
71	603045	Screw	2	Piece
	601110	Sunflower oil	0.5	Litre

Accessories

601113	Binding tape	2	Piece
601119	Mounting sleeve	1	Piece
606121	O ring set	1	Piece

EG-Konformitätserklärung (Original)*EC Declaration of Conformity*

Der Hersteller
The manufacturer

Auras Pumpen GmbH & Co. KG
Borsigallee 14
60388 Frankfurt /Main
Germany

erklärt hiermit,
herewith declares

dass die nachstehend bezeichnete Maschine
that the machinery described below

AURAS Tauchpumpen*AURAS submersible pumps***Type / type P 220, P 220 A****Type / type P 20, P 20 A****Type / type P 30, P 30 A****Type / type P 40 ND, P 40 ND A****Type / type P 40 HD, P 40 HD A****Type / type P 60 ND, P 60 ND A****Type / type P 40 CS**

hergestellt im Werk
manufactured in the plant

Auras Pumpen GmbH & Co. KG
Borsigallee 14
60388 Frankfurt /Main
Germany

Einschlägigen EG-Richtlinien*Correspond to Relevant EC directives*

2006/95/EG

2006/42/EG (+2009/127/EG)

2004/108/EG

entsprechen.

Angewandte harmonisierte Normen*Applied harmonized standards*

EN 55014-1/ A1:2009

EN 55014-2/A2:2008

EN 61000-3-2/A2:2009

EN 61000-3-3:2008

EN 60335-1:2012

EN 60335-2-41/A2:2010

EN 62233:2008

Das CE-Kennzeichen befindet sich auf dem Datenschild an der Pumpe.

Bei einer mit dem Hersteller nicht abgestimmten Änderung der Maschine verliert diese Erklärung ihre Gültigkeit.

CE-marking is on the identification plate at the pump. The declaration is no more valid, if the product is modified without agreement.

Frankfurt / Main

Alexander Schmid
Geschäftsführer / *managing director*

Auras Pumpen GmbH & Co. KG
Borsigallee 14
60388 Frankfurt am Main
Germany

Tel. +49 (0) 69 678 307 190
Fax +49 (0) 69 678 307 199
Email: info@auras-pumpen.de
Internet: www.tauchpumpen.de

AURAS

Copyright by Auras Pumpen GmbH & Co. KG, 03/2014, 60388 Frankfurt / Main. Kein Teil der Bedienungsanleitung und der Ersatzteilliste darf in irgendeiner Form (Druck, Fotokopie, Mikrofilm oder ein anderes Verfahren) ohne schriftliche Genehmigung der Firma Auras Pumpen GmbH & Co. KG reproduziert oder unter Verwendung elektronischer Systeme verarbeitet, vervielfältigt oder verbreitet werden. Irrtümer, Druckfehler und technische Änderungen vorbehalten.

Bildrechte: underwater scene © adimas #30731812

Copyright by Auras Pumpen GmbH & Co. KG, 03/2014, 60388 Frankfurt / Main. No part of the operating manual and spare parts lists may be reproduced in any form (print, photocopy, microfilm or other) or processed, duplicated or distributed by use of data processing systems without written permission of Auras Pumpen GmbH & Co. KG. No liability is assumed for errors, misprints and technical errors

Image rights: underwater scene © adimas #30731812